

[CONTRIBUTION FROM THE PACIFIC EXPERIMENT STATION, BUREAU OF MINES, UNITED STATES DEPARTMENT OF THE INTERIOR]

## A Hydrofluoric Acid Solution Calorimeter and the Determination of the Heats of Formation of $Mg_2SiO_4$ , $MgSiO_3$ , and $CaSiO_3$ <sup>1</sup>

BY D. R. TORGESON<sup>2</sup> AND TH. G. SAHAMA<sup>3</sup>

Heats of formation of most silicates are not amenable to determination by either combustion or ordinary solution calorimetry. However, many silicates can be studied with a hydrofluoric acid solution calorimeter, operating near 75°. This paper describes a calorimeter of this type and presents values of the heats of formation of magnesium orthosilicate, magnesium metasilicate and calcium metasilicate.

### Materials

The materials employed were artificial magnesium metasilicate (clinoenstatite), natural calcium metasilicate (wollastonite), a series of 6 natural solid solutions in the  $Mg_2SiO_4$ - $Fe_2SiO_4$  system with a wide range of magnesium: iron ratios, artificial ferrous orthosilicate (fayalite), natural quartz, artificial magnesium hydroxide, and artificial calcium oxide.

The magnesium metasilicate and ferrous orthosilicate were the materials used in previous measurements by Kelley.<sup>4,5</sup> The former contained 92.0%  $MgSiO_3$ , 5.6%  $Mg_2SiO_4$ , and 2.4% uncombined  $SiO_2$ . The latter was virtually 100% pure.

The calcium metasilicate was that described by Southard.<sup>6</sup> It contained about 0.6% impurities.

The quartz was the purest available grade. It was crushed, screened through 325-mesh, washed with hot hydrochloric acid for several days, water-elutriated to eliminate the coarser particles, and finally dried. Analyses indicated at least 99.9% silica content.

Magnesium hydroxide was prepared from reagent-grade magnesium oxide in a manner similar to that used by Taylor and Wells.<sup>7</sup> In this instance, the washed oxide was calcined at 900° and then hydrated with steam at 150 lb. per sq. in. pressure. The wet hydrate was dried

in vacuum at 120°. Analysis showed 0.1% carbon dioxide content (equivalent to 0.19%  $MgCO_3$ ) and 99.78% magnesium hydroxide.

Calcium oxide was prepared by calcining special reagent grade calcium carbonate at 1150°. Analysis of the product showed 99.98% calcium oxide.

The  $Mg_2SiO_4$ - $Fe_2SiO_4$  samples are described in Table I, using the classification proposed by Deer and Wager.<sup>8</sup> Before chemical analysis, the samples were purified by hand sorting, table classification, magnetic separation, and gravity separation with Clerici solution (aqueous solution of thallium formate and thallium malonate). Final products were examined microscopically.

### Apparatus and Method

The calorimetric assembly is shown in Fig. 1. As it is expected that several researches employing this equipment will be published, a brief description is warranted.

The calorimeter, V, is a cylindrical platinum vessel, 10 cm. diam. and 12.5 cm. high, filled with hydrofluoric acid to the level indicated at Y. Chimneys, V and W, provide for admission of the stirrer, X, and for insertion of samples. A cylindrical well, K, 2.2 cm. diameter, extending from 1.3 cm. above the bottom to 2.5 cm. above the top, houses the resistance thermometer and calibrating heater coils.

The resistance thermometer, L, and heater, N, are wound on the hollow copper cylinder, M, which has closed ends. This cylinder has 0.1-mm. wall thickness except at the ends where projecting flanges were left to anchor the coils and provide thermal contact with K. The resistance thermometer consists of B. & S. No. 40, single silk-covered and enameled copper wire and has 104.7 ohms resistance at 73.7°, the sensitivity being 308  $\mu V$ . per degree. (As both calibration and reaction heats are measured in terms of  $\mu v$ ., actual conversion to degrees never is necessary.) The heater is a 100-ohm coil of B. & S. No. 34, double-silk-covered manganin

TABLE I  
 $Mg_2SiO_4$ - $Fe_2SiO_4$  SAMPLES

Sample	Source	Analysis for major constituents, wt. % <sup>4</sup>						Microscopically estimated impurities
		$SiO_2$	FeO	MgO	$Fe_2O_3$	$TiO_2$	MnO	
(A) Forsterite	Dreis, Eifel, Germany	40.60	8.35	49.60	0.96	0.00	0.16	None
(B) Forsterite	Ultenthal, Tyrol, Austria	40.72	9.48	49.52	0.10	.12	0.13	None
(C) Chrysolite <sup>10</sup>	Marjalahti, Finland	40.24	10.92	48.08	0.68	.00	0.28	None
(D) Hyalosiderite	Lake Leistilänjärvi, Nakkila, Finland	35.20	35.40	25.94	2.60	.45	0.60	2% titanomagnetite
(E) Hyalosiderite <sup>11</sup>	Susimäki, Vampula, Finland	35.12	36.98	25.42	2.10	.10	0.53	0.75% magnetite and ilmenite
(F) Ferrohortonolite <sup>12</sup>	St. Utterviks Hage, Tunaberg, Södermanland, Sweden	29.80	64.06	2.22	0.00	.00	4.38	1% magnetite

(1) Published by permission of the Director, Bureau of Mines, U. S. Department of the Interior. Not copyrighted.

(2) Chemist, Pacific Experiment Station, Bureau of Mines.

(3) Professor of Geochemistry, University of Helsinki, Finland, and at present Visiting Investigator of the Carnegie Institution of Washington, associated with the staff of the Geophysical Laboratory. Acknowledgment is gratefully made of support received from the Carnegie Institution of Washington throughout the course of this work.

(4) Kelley, *This Journal*, **65**, 339 (1943).

(5) Kelley, *ibid.*, **63**, 2750 (1941).

(6) Southard, *ibid.*, **63**, 3142 (1941).

(7) Taylor and Wells, *Bur. Standards J. Research*, **21**, 133 (1938).

wire. Paraffin was used to fill the annular space between cylinder M and the walls of K. The top of K is closed by the cork, I, to which radiation shield, J, is attached.

Lead wires, A, from the resistance thermometer and

(8) Deer and Wager, *Am. Mineralogist*, **24**, 18 (1939).

(9) Chemical analyses were made by O. v. Knorring, University of Helsinki, Finland.

(10) Described by Borgström, *Bull. Comm. Geol. Finlande*, **14** (1903).

(11) Described by Palmunen, *Fennia*, **45**, No. 9 (1925).

(12) Described by Palmgren, *Bull. Geol. Inst., Upsala*, **14**, 109 (1916).

heater coils are protected from acid vapors by the bakelite tube B, which ends in the vapor seal E containing heavy silicon grease.

The calorimeter is supported by the bakelite ringstand, O, which also supports the thin, gold-plated copper surrounding shield, F.

The outer container, G, is of heavy, gold-plated brass. It is attached to the top, D, by means of a bolted flanged joint, the seal being made by a tygon gasket. The top has three chimneys in line with the calorimeter chimneys and well. Chimneys R and C, for admission of the stirrer and the lead wire protection tube, are shown in Fig. 1. A third chimney, not in the plane of the drawing, admitted samples.

The stirrer, X, is pure platinum. Attachment to the drive mechanism is made through the teflon assembly Q-T which also houses two sets of ball bearings. The lower part of T serves as a closure for calorimeter chimney V.

The entire assembly is immersed in an oil-bath to the level indicated at U. The oil bath is thermostatically controlled at  $73.7 \pm 0.1^\circ$ .

Readings of resistance thermometer e. m. f. and calibrating heater current are made with a White 100,000  $\mu$  v. range double potentiometer. This instrument also serves in fixing and maintaining constant the resistance thermometer current which is  $900.000 \pm 0.002 \mu$  amp. Energy input times for calibrations are measured with a stopwatch, calibrated against a standard chronometer of the Astronomy Department of the University of California. The resistance of the manganin heater coil is determined at operating temperature by direct comparison with a 100-ohm standard resistance.

All samples are contained in gelatin capsules, sizes O and OO being the most convenient. These are dropped from room temperature through chimney W into the calorimeter at operating temperature. Platinum weights are enclosed with the samples to assure immediate sinking of capsule and contents.

In each heat of reaction measurement, 856.0 g. of 20.1% (by weight) hydrofluoric acid was used. Amounts of reacting materials were in stoichiometric proportion: 0.6750 g. of quartz, 1.1281 g. of magnesium metasilicate, 2.2900 g. of ferrous orthosilicate, 0.6556 g. of magnesium hydroxide, 1.3053 g. of calcium metasilicate, 0.6303 g. of calcium oxide, 1.6482 g. of sample A, 1.6510 g. of sample B, 1.6649 g. of sample C, 1.8931 g. of sample D, 1.9061 g. of sample E, and 2.2482 g. of sample F (all corrected to vacuum).

Reagent grade hydrofluoric acid was employed. This was obtained in case lots consisting of 25 one-pound plastic bottles of approximately 48% acid. The case lots were sampled for uniformity and analyzed in transparent bakelite containers by titration against standard alkali. Each 856.0 g. batch of 20.1% acid was made up separately by weight, correction being made to vacuum.

The time required for complete reaction and attainment of final steady state conditions after dropping a sample into the calorimeter ranged from ten to thirty minutes, depending upon the substance. The temperature rise varied from 120.70  $\mu$ v. for magnesium hydroxide to 400.64  $\mu$ v. for olivine A.

All heat-of-reaction values are adjusted to correspond with the process, Reactant (solid,  $25^\circ$ )  $\rightarrow$  Product ( $73.7^\circ$ ). This was accomplished by measuring the temperature of the gelatin capsule and contents just before dropping into the calorimeter and making the minor correction resulting from deviation of room temperature from  $25^\circ$ . Although reaction with the hydrofluoric acid occurs at  $73.7^\circ$ , this method of adjustment leads to values of heats of formation at  $25^\circ$ .

Measured heats of reaction were corrected for the sensible heat and heat of solution of the gelatin capsules. For the process, gelatin (solid,  $25^\circ$ )  $\rightarrow$  gelatin (in solution,  $73.7^\circ$ ), six measurements gave, respectively, 22.06, 22.15, 22.80, 22.79, 22.85, and 22.63 cal. per g., the mean being  $22.63 \pm 0.22$  cal. per g. The gelatin correction ranged from 1 to 2%, depending upon the substance. Correction, from 0.2 to 1%, also was made for the sensible

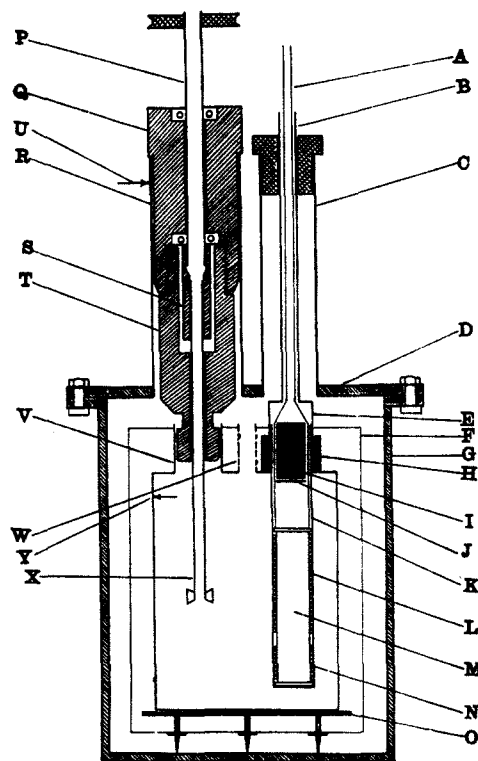

Fig. 1.—Hydrofluoric acid solution calorimeter.

heat in the platinum sinkers, using  $H_{73.7} - H_{25.0} = 1.70$  cal. per g. The magnitude of the corrections for impurities will be considered later.

An electrical calibration was made either just before or just after each heat-of-reaction measurement, in terms of the defined calorie (1 cal. = 4.1833 int. joules).<sup>13</sup> The maximum spread in calibration values during the course of this work was 0.2%.

### Measurements and Results

Each of the heats of formation is obtained as a resultant of the measurement of the heats of several reactions for which skeleton equations are given in Tables II, III, and V. The method of ascribing uncertainties to the individual reaction heat values and their resultant follows Rossini and Deming.<sup>14</sup>

**Heat of Formation of  $MgSiO_3$ .**—Table II summarizes the data for obtaining the heat of formation of magnesium metasilicate from the component oxides. In this and subsequent tables various symbols are employed: c = crystals, l = liquid, p = precipitate, and sol. = in solution.

Six determinations of the heat of reaction (1) were made, the results being  $-29,901$ ,  $-29,102$ ,  $-29,069$ ,  $-29,095$ ,  $-29,060$  and  $-29,111$  cal. per mole. The mean is  $-29,090 \pm 20$ . These results include a net correction of 35 cal. for the 0.19% magnesium carbonate impurity. By net correction is meant the difference between the actual reported value and what would have been reported if the impurity had been neglected. It

(13) Mueller and Rossini, *Am. J. Physics*, **12**, 1 (1944).

(14) Rossini and Deming, *J. Wash. Acad. Sci.*, **29**, 416 (1939).

TABLE II  
HEAT OF FORMATION OF  $MgSiO_3$  (CLINOENSTATITE) (CAL. PER MOLE)

Reaction	$\Delta H$	Uncertainty
(1) $Mg(OH)_2$ (c, 25°) + 2HF (sol., 73.7°) $\rightarrow$ $MgF_2$ (p, 73.7°) + 2H <sub>2</sub> O (sol., 73.7°)	-29,090	20
(2) $SiO_2$ (c, 25°) + 6HF (sol., 73.7°) $\rightarrow$ $H_2SiF_6$ (sol., 73.7°) + 2H <sub>2</sub> O (sol., 73.7°)	-33,000	20
(3) $MgSiO_3$ (c, 25°) + 8HF (sol., 73.7°) $\rightarrow$ $MgF_2$ (p, 73.7°) + $H_2SiF_6$ (sol., 73.7°) + 3H <sub>2</sub> O (sol., 73.7°)	-63,060	140
(4) $MgO$ (c, 25°) + H <sub>2</sub> O (l, 25°) $\rightarrow$ $Mg(OH)_2$ (c, 25°)	- 8,850	25
(5) H <sub>2</sub> O (l, 25°) $\rightarrow$ H <sub>2</sub> O (sol., 73.7°)	810	5
(6) $MgO$ (c, 25°) + $SiO_2$ (c, 25°) $\rightarrow$ $MgSiO_3$ (c, 25°)	- 8,690	150

$$\Delta H_6 = \Delta H_1 + \Delta H_2 - \Delta H_3 + \Delta H_4 - \Delta H_5$$

should be noted that to make the final solution from reaction (1) equivalent in  $H_2SiF_6$  content to those of reactions (2) and (3), the magnesium hydroxide reacted with a solution in which had already been dissolved the stoichiometrical amount of silica.

Seven determinations of the heat of reaction (2) gave -33,003, -33,033, -32,981, -32,983, -33,003, -33,008, and -33,019 cal. per mole, the mean being -33,000  $\pm$  20. These values include a net correction of 40 cal. for adsorbed water, which was determined to be about 0.1%.

For reaction (3), seven values of the heat were measured. The results are -62,869, -63,195, -63,059, -63,299, -63,232, -62,893, and -62,899 cal. per mole. The mean is -63,060  $\pm$  140. The net correction included for impurities, magnesium orthosilicate and uncombined silica, is 90 cal.

The heat of reaction (4), the hydration of magnesium oxide, was not determinable in the hydrofluoric acid calorimeter because of slowness of reaction of the oxide. Recourse was taken to the ordinary solvents calorimeter described by Southard<sup>15</sup> and Young<sup>16</sup> and used by Shomate and Huffman<sup>17</sup> in their determination of the heat of formation of magnesium oxide.

Six determinations of the heat of solution of magnesium hydroxide in 1.000 *N* hydrochloric acid were conducted under conditions virtually identical with those of Shomate and Huffman for the oxide and with equivalent stoichiometrical amounts of materials. The results were -26,948, -26,957, -26,953, -26,942, -26,948, and -26,968 cal. per mole. The mean. -26,950  $\pm$  10, is  $\Delta H_{298.16}$  for the reaction

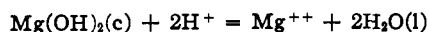

(15) Southard, *Ind. Eng. Chem.*, **32**, 442 (1940).

(16) Young, *THIS JOURNAL*, **67**, 257 (1945).

(17) Shomate and Huffman, *ibid.*, **65**, 1625 (1943).

Corrections included in these results are 10 cal. for the heat of dilution by the two moles of water formed in the reaction and 35 cal. net correction for the magnesium carbonate impurity. Shomate and Huffman obtained  $\Delta H_{298.16} = -35,799 \pm 21$  cal. per mole for the reaction



Combination of these values leads to  $\Delta H_{298.16} = -8,850 \pm 25$  cal. per mole for the reaction

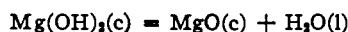

which is reaction (4) of Table II.

Four determinations of the heat of reaction (5) were made, obtaining 816, 815, 811 and 807, with a mean of 810  $\pm$  5 cal. per mole. Because of the low heat, these determinations were made with 8 to 12 times the stoichiometrical amount of water, to realize a higher over-all accuracy. To be specific, amounts of water ranging from 1.597 g. to 2.418 g. were dissolved in 856.0 g. of 20.1% hydrofluoric acid to which had already been added amounts of magnesium hydroxide and silica corresponding to those employed in reactions (1) and (2).

The summation,  $\Delta H_6 = \Delta H_1 + \Delta H_2 - \Delta H_3 + \Delta H_4 - \Delta H_5$ , gives  $\Delta H_{298.16} = -8,690 \pm 150$  as the heat of formation of magnesium metasilicate from magnesium oxide and quartz.

**Heat of Formation of  $Mg_2SiO_4$ .**—Data for obtaining the heat of formation of magnesium orthosilicate are summarized in Table III.

TABLE III  
HEAT OF FORMATION OF  $Mg_2SiO_4$  (FORSTERITE) (CAL. PER MOLE)

Reaction	$\Delta H$	Uncertainty
(7) $2Mg(OH)_2$ (c, 25°) + 4HF (sol., 73.7°) $\rightarrow$ $2MgF_2$ (p, 73.7°) + 4H <sub>2</sub> O (sol., 73.7°)	-58,180	40
(8) $SiO_2$ (c, 25°) + 6HF (sol., 73.7°) $\rightarrow$ $H_2SiF_6$ (sol., 73.7°) + 2H <sub>2</sub> O (sol., 73.7°)	-33,000	20
(9) $Mg_2SiO_4$ (c, 25°) + 10HF (sol., 73.7°) $\rightarrow$ $2MgF_2$ (p, 73.7°) + $H_2SiF_6$ (sol., 73.7°) + 4H <sub>2</sub> O (sol., 73.7°)	-95,380	200
(10) $2MgO$ (c, 25°) + 2H <sub>2</sub> O (l, 25°) $\rightarrow$ $2Mg(OH)_2$ (c, 25°)	-17,700	50
(11) $2H_2O$ (l, 25°) $\rightarrow$ 2H <sub>2</sub> O (sol., 73.7°)	1,620	10
(12) $2MgO$ (c, 25°) + $SiO_2$ (c, 25°) = $Mg_2SiO_4$ (c, 25°)	-15,120	210

$$\Delta H_{12} = \Delta H_7 + \Delta H_8 - \Delta H_9 + \Delta H_{10} - \Delta H_{11}$$

Heats of reactions (8), (10), and (11) were discussed previously as heats of reactions (2), (4) and (5), respectively. Reaction (7) is the same as reaction (1) except that twice the amount of magnesium hydroxide is concerned. However, it was determined quantitatively that no measurable difference in molal heat of reaction resulted from

TABLE IV  
HEATS OF REACTION OF  $Fe_2SiO_4$  AND  $Mg_2SiO_4-Fe_2SiO_4$  SOLID SOLUTIONS WITH 20.1% HYDROFLUORIC ACID

Sample	Number of detns.	Composition, mole %		Net correction for impurities	$\Delta H$ , cal./mole		
		$Mg_2SiO_4$	$Fe_2SiO_4$		Meas.	Calcd.	Diff.
A	4	90.6	9.4	100	-94,250 $\pm$ 160	-94,060	-190
B	4	90.2	9.8	70	-93,590 $\pm$ 80	-94,000	410
C	5	88.2	11.8	160	-93,930 $\pm$ 140	-93,720	-210
D	4	56.0	44.0	590	-89,070 $\pm$ 100	-89,200	130
E	4	54.2	45.8	470	-88,820 $\pm$ 160	-88,940	120
F	4	5.9	94.1	750	-82,080 $\pm$ 160	-82,160	80
$Fe_2SiO_4$	6	0.0	100.0	0	-81,330 $\pm$ 50	-81,330	0

the use of 1.3112 g. rather than 0.6556 g. of magnesium hydroxide with 856.0 g. of hydrofluoric acid. Consequently, the heat of reaction (7) is just twice that of reaction (1).

The heat of reaction (9) was obtained by extrapolation of results for the  $Mg_2SiO_4-Fe_2SiO_4$  solid solutions. This was necessary because a suitable sample of pure magnesium orthosilicate was not available. Table IV summarizes the heat of reaction data for the six solid solutions and for pure ferrous orthosilicate. Corrections were made for the principal impurities, the net correction being shown in column (5) and the resulting adjusted molal composition in columns (3) and (4).

The mean measured values in column (6) are represented by

$$\Delta H = -81,330 - 140.5 X_{Mg}$$

in which  $X_{Mg}$  is the molal % of magnesium orthosilicate. Values calculated from the equation are in column (7). Extrapolation to 100% magnesium orthosilicate leads to  $\Delta H = -95,380 \pm 200$  cal. per mole, which is the value adopted for the heat of reaction (9).

The summation,  $\Delta H_{12} = \Delta H_7 + \Delta H_8 - \Delta H_9 + \Delta H_{10} - \Delta H_{11}$ , gives  $\Delta H_{298.16} = -15,120 \pm 210$  as the heat of formation of magnesium orthosilicate from magnesium oxide and quartz.

**Heat of Formation of  $CaSiO_3$ .**—Data for obtaining the heat of formation of calcium metasilicate are summarized in Table V.

TABLE V  
HEAT OF FORMATION OF  $CaSiO_3$  (WOLLASTONITE) (CAL. PER MOLE)

Reaction	$\Delta H$	Uncertainty
(13) $CaO$ (c, 25°) + 2HF (sol., 73.7°) $\rightarrow$ $CaF_2$ (p, 73.7°) + $H_2O$ (sol., 73.7°)	-54,960	20
(14) $SiO_2$ (c, 25°) + 6HF (sol., 73.7°) $\rightarrow$ $H_2SiF_6$ (sol., 73.7°) + 2 $H_2O$ (sol., 73.7°)	-33,000	20
(15) $CaSiO_3$ (c, 25°) + 8HF (sol., 73.7°) $\rightarrow$ $CaF_2$ (p, 73.7°) + $H_2SiF_6$ (sol., 73.7°) + 3 $H_2O$ (sol., 73.7°)	-66,710	120
(16) $CaO$ (c, 25°) + $SiO_2$ (c, 25°) $\rightarrow$ $CaSiO_3$ (c, 25°)	-21,250	130

$\Delta H_{16} = \Delta H_{13} + \Delta H_{14} - \Delta H_{15}$

Six determinations of the heat of reaction (13) gave -54,973, -54,974, -54,937, -54,965, -54,963, and -54,959 cal. per mole, the mean being -54,960  $\pm$  20.

The heat of reaction (14) was discussed previously as the heat of reaction (2). Six measurements were made of the heat of reaction (15). The results are -66,711, -66,785, -66,795, -66,705, -66,605, and -66,681 cal. per mole. The mean is -66,710  $\pm$  120. In this instance the calculated uncertainty has been doubled, an estimated allowance for neglect of impurities.

The summation,  $\Delta H_{16} = \Delta H_{13} + \Delta H_{14} - \Delta H_{15}$ , gives  $\Delta H_{298.16} = -21,250 \pm 130$  as the heat of formation of calcium metasilicate from calcium oxide and quartz.

### Discussion

The only previous data with which comparison can be made are for wollastonite. Bichowsky and Rossini<sup>18</sup> list a heat-of-formation value for 291.16°K. that corresponds to -22,800 cal. per mole for the heat of formation of wollastonite from calcium oxide and quartz. Their result is a weighted mean of values covering a range of some 10,000 cal. The two best of these values appear to be those attributed to Roth and Chall and Wagner which lead, respectively, to -19,660 and -21,460 cal. per mole heat of formation from the oxides. A more recent value of Troitzsch<sup>19</sup> is -21,750 cal. per mole at 293.16°K. The present value,  $\Delta H_{298.16} = -21,250$ , intermediates these results and is considered the most reliable.

Using entropy data listed by Kelley<sup>20,21</sup> the reported heat values lead to the following free energies of formation from the component oxides:  $\Delta F_{298.16}^0 = -8,540 \pm 160$  for magnesium metasilicate,  $\Delta F_{298.16}^0 = -14,970 \pm 230$  for magnesium orthosilicate, and  $\Delta F^0 = -21,250 \pm 160$  for calcium metasilicate.

### Summary

A hydrofluoric acid solution calorimeter, employing 20% acid and operating near 75°, is described.

(18) Bichowsky and Rossini, "Thermochemistry of the Chemical Substances," Reinhold Publishing Corporation, New York, N. Y., 1936.

(19) Landolt-Börnstein, "Physikalisch-chemische Tabellen," Julius Springer, Berlin, 3rd Supplement, vol. 3, 1936, p. 2763.

(20) Kelley, *Bureau of Mines Bulletin*, 434 (1941).

(21) Kelley, *THIS JOURNAL*, 65, 339 (1943).

Heats of formation from the component oxides were obtained for magnesium metasilicate, magnesium orthosilicate, and calcium metasilicate by

measuring heats of solution and reaction of the pertinent substances in hydrofluoric acid.

BERKELEY, CALIFORNIA

RECEIVED JANUARY 30, 1948

CONTRIBUTION FROM THE PACIFIC EXPERIMENT STATION, BUREAU OF MINES, UNITED STATES DEPARTMENT OF THE INTERIOR]

## High-Temperature Heat Contents of $3\text{CaO}\cdot\text{B}_2\text{O}_3$ , $2\text{CaO}\cdot\text{B}_2\text{O}_3$ , $\text{CaO}\cdot\text{B}_2\text{O}_3$ , and $\text{CaO}\cdot 2\text{B}_2\text{O}_3$ <sup>1</sup>

BY E. G. KING,<sup>2</sup> D. R. TORGESON<sup>2</sup> AND O. A. COOK<sup>3</sup>

In two recent papers,<sup>4,5</sup> heats of formation and low-temperature heat-capacity and entropy data were presented for the four calcium borates,  $3\text{Ca}\cdot\text{B}_2\text{O}_3$ ,  $2\text{CaO}\cdot\text{B}_2\text{O}_3$ ,  $\text{CaO}\cdot\text{B}_2\text{O}_3$ , and  $\text{CaO}\cdot 2\text{B}_2\text{O}_3$ . These are all the compounds in the  $\text{CaO}\text{--}\text{B}_2\text{O}_3$  system, according to the work of Carlson.<sup>6</sup> The present paper reports high temperature heat content values, thus completing basic data needed for thermodynamic calculations of reactions of these compounds in both the crystalline and liquid states. The results have additional interest in that this is the first complete series of interoxidic

compounds for which high temperature heat content measurements have been carried beyond the melting points so that adequate heat of fusion values are available. No previous high temperature heat content data exist for any of these substances.

### Method and Materials

Measurements were made by the "dropping" method, using previously described apparatus.<sup>7,8</sup> During measurement, the samples were enclosed in platinum-rhodium alloy capsules, pure platinum being used in welding shut the capsule necks after evacuating and filling the pore space with helium. The heat contents of the empty capsules were determined by separate experiments. At the highest temperatures, small pinholes developed in the capsules, and it was necessary to weigh capsules and contents after each measurement. The total loss in weight during a complete series of measurements never exceeded 0.5% of the original sample weight. Correction was made on the assumption that boric oxide was lost by volatilization and that the equivalent amount of the borate next higher in calcium oxide had formed. As the net correction always was less than 0.2%, no appreciable error in reported results is involved.

The preparation, analysis, and X-ray diffraction examination of the borates was described by Torgeson and Shomate,<sup>4</sup> whose samples also were used in the present work. It should be noted that the sharpness of the observed melting points and the agreement with results of the National Bureau of Standards<sup>6,9</sup> substantiates the purity of the materials.

### Results and Discussion

The experimental heat content values are given in Table I and Figs. 1 and 2, being expressed in defined calories (1 cal. = 4.1833 int. joules)<sup>10</sup> per mole (in vacuum) of borate. Molal weights accord with the 1947 International Atomic Weights. Values marked (t) and (p) show, respectively, effects of pretransition and of premelting or in-

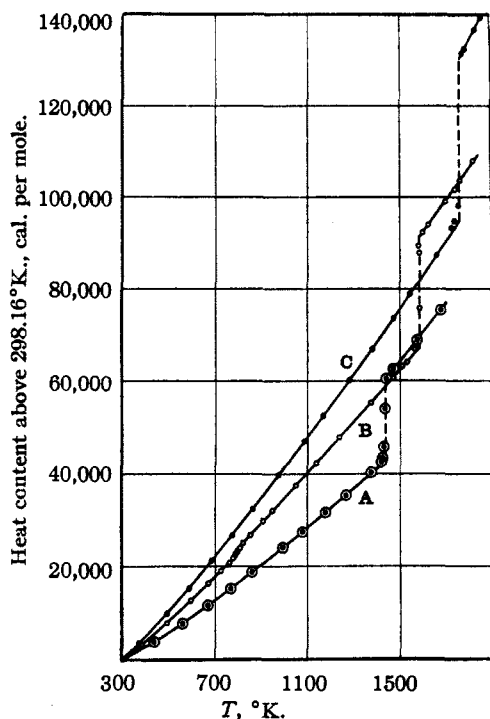

Fig. 1.—Heat contents of calcium borates: A,  $\text{CaO}\cdot\text{B}_2\text{O}_3$ ; B,  $2\text{CaO}\cdot\text{B}_2\text{O}_3$ ; C,  $3\text{CaO}\cdot\text{B}_2\text{O}_3$ .

(1) Published by permission of the Director, Bureau of Mines, U. S. Department of the Interior. Not copyrighted.

(2) Chemist, Pacific Experiment Station, Bureau of Mines.

(3) Formerly chemist, Pacific Experiment Station, Bureau of Mines.

(4) Torgeson and Shomate, *THIS JOURNAL*, **69**, 2103 (1947).

(5) Kelley, Todd and Shomate, *ibid.*, accepted for publication.

(6) Carlson, *Bur. Standards J. Research*, **9**, 825 (1932).

(7) Southard, *THIS JOURNAL*, **63**, 3142 (1941).

(8) Kelley, Naylor and Shomate, *Bur. Mines Tech. Paper* **686** (1946), 34 pp.

(9) Flint and Wells, *Bur. Standards J. Research*, **17**, 727 (1936).

(10) Mueller and Rossini, *Am. J. Phys.*, **12**, 1 (1944).